

# Electric Guitar Pickups

Kirk T. McDonald

Joseph Henry Laboratories, Princeton University, Princeton, NJ 08544

(May 6, 2007)

## 1 Problem

The conversion of sound and music to electrical signals, and *vice versa*, began with the invention of the telephone by Gray and Bell in 1875 [1, 2]. Here, the musical instrument produces sound waves, which actuate a mechanical transducer that leads to a variable electrical resistance (Gray) or a variable magnetic flux through a coil (Bell). The latter scheme is shown in the figure below

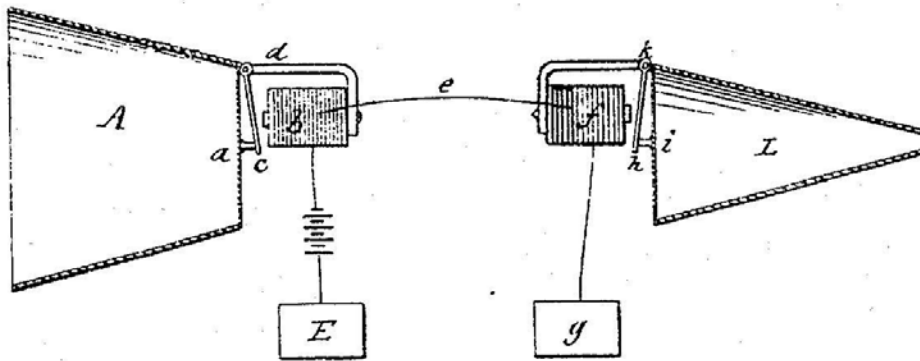

A more direct coupling between musical instruments and magnetic coils was introduced by Lloyd Loar, an instrument maker for Gibson, in the 1920's [3, 4]. In Loar's electrical stringed instruments the vibrations of a sound board actuated the pickup coil (which term Loar used), as sketched in the figure below.

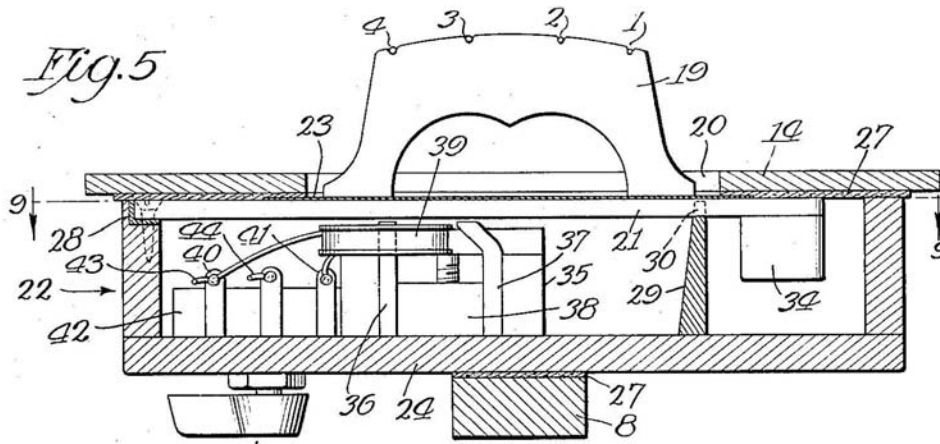

A further increase in the directness of the coupling of a stringed instrument to a magnetic coil was introduced around 1930 by Miessner [5] and others, in which the vibrations of strings made of permeable magnetic material (such as steel) cause variations in the magnetic flux through a pickup coil wrapped around a permanent magnet, as sketched in the figure on the next page.

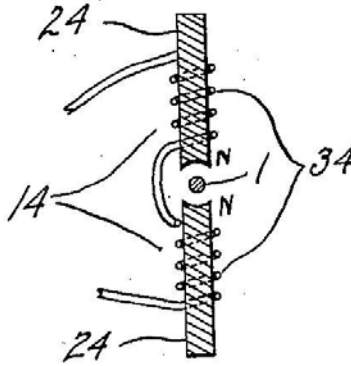

The concept of an electro-acoustic pickup based on permeable strings and coils wound around permanent magnets has been vastly elaborated over the last 70 years, leading to a musical esthetic in which the “defects” in the fidelity of the pickup coils are considered as desirable attributes. The prototype of the contemporary electric guitar based on this type of pickup is generally considered to be the 1931 “frying pan” guitar (whose pickup is shown in the figure below) of Beauchamp [6], who worked for Rickenbacker Electro [7].<sup>1</sup>

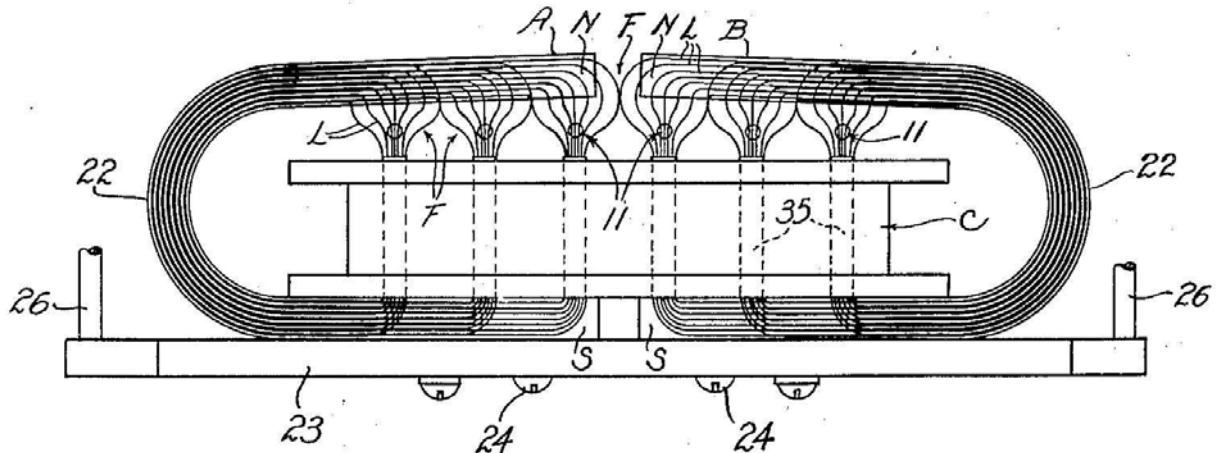

An alternative concept for the pickup has a conducting (but not permeable) string that is part of a closed electrical loop, as shown in the figure below [8]. When the string vibrates in the presence of a permanent magnet, a voltage is induced around the loop, according to Faraday’s law. While this technique has not found much application in musical instruments, it has been used by the author as a noninvasive method for measuring the tension of wires [9].

<sup>1</sup>The electric guitar as we know it today includes the innovation of Les Paul in 1941 that eliminated the hollow acoustic chamber of the classical guitar in favor of exclusive use of the harmonic content of the electromagnetic pickup.

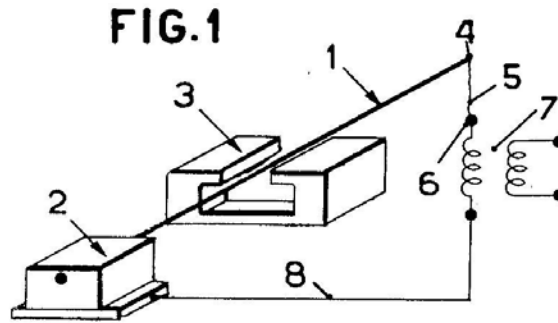

In this problem you will consider a simplified model of the magnetic coupling between the steel string (of radius  $a$  and relative magnetic permeability  $\mu_{\text{rel}}$ ) and the pickup coil (of area  $w \times w$ ), as shown in the figure below. When at rest the string is height  $h$  above the pickup coil. The vibration of the string parallel to the face of the guitar is described by  $x(t)$ , and that perpendicular to the face by  $y(t)$ . At all times the string is immersed in a uniform magnetic field  $B_0$  that is perpendicular to the face of the guitar.

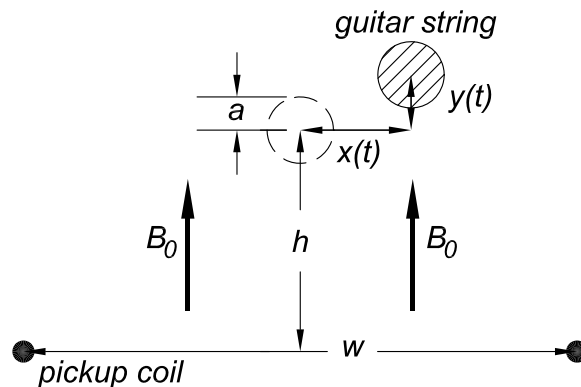

Deduce the magnetic field when the string is displaced by  $(x, y)$  from its rest position, and from this deduce the voltage  $V(t)$  induced in the pickup coil by the vibrating string.

The pickup voltage is affected by the position of the coil along the string, as discussed in [10]. The electrical signal from the guitar to the external amplifier is modified by the R-L-C circuit whose inductance is that of the pickup coil, which circuit acts as a (wide) bandpass filter [11].

## 2 Solution

We first suppose the guitar string (of radius  $a$  and relative permeability  $\mu_{\text{rel}}$ ) is centered on the  $z$ -axis in a uniform magnetic field  $B_0 \hat{y}$  that is produced by a permanent magnet.

As there are no conduction currents in the string or in the permanent magnet,<sup>2</sup> the magnetic field  $\mathbf{H}$  obeys  $\nabla \times \mathbf{H} = 0$ . Hence, the magnetic field  $\mathbf{H}$  can be deduced from a (magnetic) scalar potential  $\phi$ , according to

$$\mathbf{H} = -\nabla\phi. \tag{1}$$

---

<sup>2</sup>We ignore the tiny magnetic field due to the current induced in the pickup coil.

The field  $\mathbf{H}_0$  of the permanent magnet can be written

$$\mathbf{H}_0 = \frac{\mathbf{B}_0}{\mu_0} = \frac{B_0}{\mu_0} \hat{\mathbf{y}} = \frac{d}{dy} \frac{B_0 y}{\mu_0} \hat{\mathbf{y}} = -\nabla \frac{-B_0 y}{\mu_0} = -\nabla \frac{-B_0 r \sin \theta}{\mu_0}, \quad (2)$$

where we introduce the cylindrical coordinate system  $(r, \theta, z)$  in the last form of eq. (2).

The full scalar potential also varies as  $\sin \theta$ , and can be written as

$$\phi(r < a) = \frac{-B_0 r \sin \theta}{\mu_0} + A \frac{r}{a} \sin \theta, \quad (3)$$

$$\phi(r > a) = \frac{-B_0 r \sin \theta}{\mu_0} + A \frac{a}{r} \sin \theta, \quad (4)$$

in terms of the to-be-determined constant  $A$ .

Maxwell's equation  $\nabla \cdot \mathbf{B} = 0$  implies that the radial component of the magnetic field  $\mathbf{B} = \mu \mathbf{H}$  is continuous across the surface of the string at  $r = a$ ,

$$\begin{aligned} B_r(r = a^-) &= \mu_{\text{rel}} \mu_0 H_r(r = a^-) = -\mu_{\text{rel}} \mu_0 \frac{\partial \phi(r = a^-)}{\partial r} = \mu_{\text{rel}} \left( B_0 + \frac{\mu_0 A}{a} \right) \sin \theta \\ &= B_r(r = a^+) = -\mu_0 \frac{\partial \phi(r = a^+)}{\partial r} = \left( B_0 - \frac{\mu_0 A}{a} \right) \sin \theta, \end{aligned} \quad (5)$$

and hence,

$$A = \frac{a B_0}{\mu_0} \frac{1 - \mu_{\text{rel}}}{1 + \mu_{\text{rel}}}. \quad (6)$$

The scalar potential outside the string is therefore,

$$\phi(r > a) = -\frac{B_0}{\mu_0} \left( r + \frac{a^2 \mu_{\text{rel}} - 1}{r \mu_{\text{rel}} + 1} \right) \sin \theta. \quad (7)$$

The magnetic field components in cylindrical coordinates are

$$B_r(r > a) = -\mu_0 \frac{\partial \phi(r > a)}{\partial r} = B_0 \left( 1 - \frac{a^2 \mu_{\text{rel}} - 1}{r^2 \mu_{\text{rel}} + 1} \right) \sin \theta, \quad (8)$$

$$B_\theta(r > a) = -\frac{\mu_0}{r} \frac{\partial \phi(r > a)}{\partial \theta} = B_0 \left( 1 + \frac{a^2 \mu_{\text{rel}} - 1}{r^2 \mu_{\text{rel}} + 1} \right) \cos \theta. \quad (9)$$

So long as the relative permeability is large compared to unity, the factor  $(\mu_{\text{rel}} - 1)/(\mu_{\text{rel}} + 1)$  is essentially one, and the behavior of the electric guitar does not depend on the precise value of the permeability of the string.

We are interested in the magnetic flux through a coil that lies in a plane of constant  $y$ , so we need the component  $B_y$  for  $r > a$ ,

$$B_y(r > a) = B_r \sin \theta + B_\theta \cos \theta = B_0 \left( 1 + a^2 \frac{\mu_{\text{rel}} - 1}{\mu_{\text{rel}} + 1} \frac{y^2 - x^2}{(x^2 + y^2)^2} \right). \quad (10)$$

The magnetic flux  $\Phi$  through a loop of area  $w \times w$  that extends from  $x_l - w/2$  to  $x_l + w/2$  at height  $y_l$  is

$$\Phi = w \int_{x_l - w/2}^{x_l + w/2} B_y(x, y_l) dx = B_0 w \left[ w + a^2 \frac{\mu_{\text{rel}} - 1}{\mu_{\text{rel}} + 1} \left( \frac{x_l + w/2}{(x_l + w/2)^2 + y_l^2} - \frac{x_l - w/2}{(x_l - w/2)^2 + y_l^2} \right) \right]. \quad (11)$$

We have calculated this flux in a coordinate system centered on the (vibrating) string. We now switch to a (lab frame) coordinate system whose origin is at the rest position of the string. The string is at  $(x, y)$  in this coordinate system, and the offsets between the string and the center of the loop are  $x_l = x$  and  $y_l = y + h$ . Using these offsets in eq. (11), the magnetic flux through the coil is

$$\begin{aligned} \Phi &= B_0 w \left[ w + a^2 \frac{\mu_{\text{rel}} - 1}{\mu_{\text{rel}} + 1} \left( \frac{x + w/2}{(x + w/2)^2 + (y + h)^2} - \frac{x - w/2}{(x - w/2)^2 + (y + h)^2} \right) \right] \\ &= B_0 w \left[ 1 + a^2 \frac{\mu_{\text{rel}} - 1}{\mu_{\text{rel}} + 1} \frac{(y + h)^2 - x^2 + w^2/4}{(x^2 - w^2/4)^2 + 2(x^2 + w^2/4)(y + h)^2 + (y + h)^4} \right] \end{aligned} \quad (12)$$

The voltage  $V$  induced in the pickup coil by the time variation of the magnetic flux is

$$\begin{aligned} V = -\dot{\Phi} &= B_0 a^2 w^2 \frac{\mu_{\text{rel}} - 1}{\mu_{\text{rel}} + 1} \left\{ \frac{2x\dot{x}[3(y + h)^4 + 2(x^2 + w^2/4)(y + h)^2 - (x^2 - w^2/4)^2]}{[(x^2 - w^2/4)^2 + 2(x^2 + w^2/4)(y + h)^2 + (y + h)^4]^2} \right. \\ &\quad \left. \frac{\dot{y}[2(y + h)^5 - 4(x^2 - w^2/4)(y + h)^3 + (6x^4 - x^2 w^2/2 - w^4/8)(y + h)]}{[(x^2 - w^2/4)^2 + 2(x^2 + w^2/4)(y + h)^2 + (y + h)^4]^2} \right\} \\ &\approx B_0 a^2 w^2 \frac{\mu_{\text{rel}} - 1}{\mu_{\text{rel}} + 1} \left[ 2x\dot{x} \frac{3h^2 - w^2/4}{(h^2 + w^2/4)^3} + \frac{2h\dot{y}}{(h^2 + w^2/4)^2} \right], \end{aligned} \quad (13)$$

where the approximation holds for  $x$  and  $y$  small compared to distances  $h$  and  $w$ . The intricate form of eq. (13) shows that even for vibrations of the wire at a pure frequency  $f$ , the voltage induced in the pickup coil has a complex harmonic structure. The approximate form of eq. (13) reveals that the fundamental frequency in the pickup coil is due only to the  $y$  vibration, *i.e.*, the vibration perpendicular to the face of the guitar. The  $x$  vibration (parallel to the face of the guitar) induces only second harmonic and higher frequencies (since if  $x = \sin(\omega t)$  then  $2x\dot{x} = \omega \sin(2\omega t)$ ). Furthermore, if the wire is close to the pickup coil, such that  $h = w/\sqrt{12}$ , the 2nd harmonic pickup of the  $x$  vibration is suppressed.

Thus, the electric guitar pickup does not generate an accurate reproduction of the direct acoustic sound of the guitar, but rather creates a more complex waveform, leading to a distinct musical esthetic.

The figures on the next page illustrate the voltage waveform (13) for the case that the magnetic field strength is  $B_0 = 1000$  gauss, the wire radius is  $a = 0.25$  mm, the width of the pickup coil is  $w = 1$  cm, the height of the wire above the pickup coil is  $h = 5$  mm, the pickup coil contains 1000 turns, and the wire vibrates at frequency  $f = 100$  Hz. The left figure shows the small voltage induced by the motion of the wire in  $x$ , parallel to the face of the guitar, while the right figure shows the total induced voltage. The latter has a strong component at the fundamental frequency of 100 Hz, but the voltage due to the  $x$  vibration is primarily at the second harmonic frequency, 200 Hz.

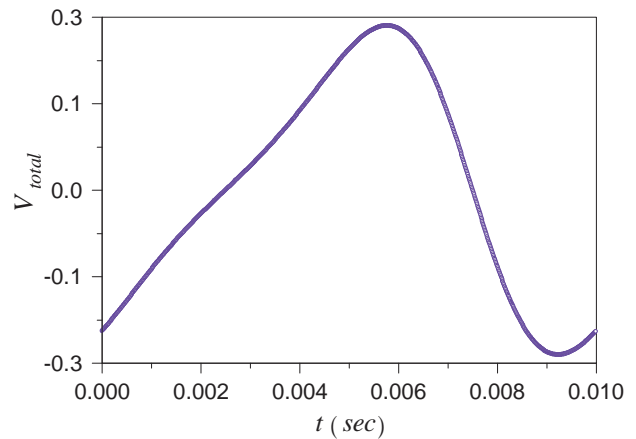
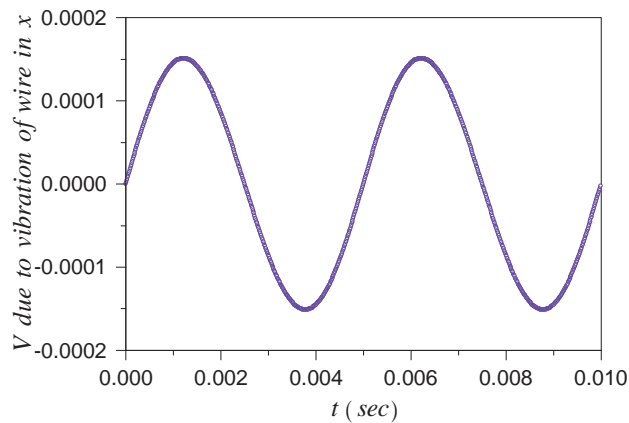

A Fourier analysis [12] of these voltage waveforms is shown in the figures below. The left figure is the voltage due to the  $x$  vibration of the string, and has significant frequency components only at the second and fourth harmonics. The right figure is the total induced voltage (almost entirely due to the  $y$  vibration of the string), which contains frequency components at all harmonics of the fundamental, with exponentially decreasing strength as a function of the harmonic number.

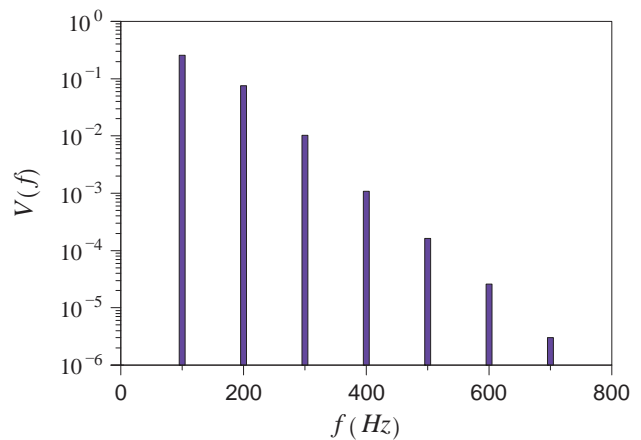
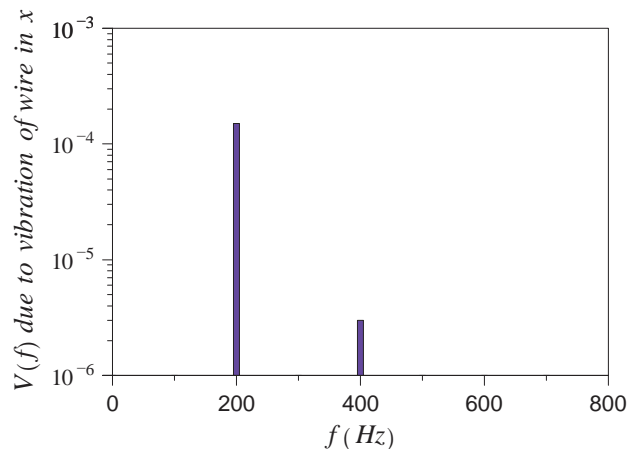

Although the wire has been assumed to vibrate with a single frequency, the voltage waveform  $V(t)$  is nearly triangular in shape. Recall that a plucked string has a triangular waveform [13], so the “distortion” of an electric guitar pickup tends to “sharpen” the plucked sound of the instrument, which has proven to be a very popular effect.

For a similar analysis, see [14].

## References

- [1] E. Gray, *Electrical Telegraph for Transmitting Musical Tones*, US Patent 166096 (July 27, 1875), [http://puhep1.princeton.edu/~mcdonald/examples/patents/gray\\_0166096.pdf](http://puhep1.princeton.edu/~mcdonald/examples/patents/gray_0166096.pdf)
- [2] A.G. Bell, *Telegraphy*, US Patent 174465 (Mar. 7, 1876), [http://puhep1.princeton.edu/~mcdonald/examples/patents/bell\\_0174465.pdf](http://puhep1.princeton.edu/~mcdonald/examples/patents/bell_0174465.pdf)
- [3] Lloyd Allayre Loar, [http://www.siminoff.net/pages/loar\\_background.html](http://www.siminoff.net/pages/loar_background.html)

- [4] L.A. Loar, *Stringed Musical Instrument*, US Patent 2020842 (filed July 31, 1933),  
[http://puhep1.princeton.edu/~mcdonald/examples/patents/loar\\_2020842.pdf](http://puhep1.princeton.edu/~mcdonald/examples/patents/loar_2020842.pdf)
- [5] B.F. Miessner, *Method and Apparatus for the Production of Music*, US Patent 1915858 (filed Apr. 9, 1931),  
[http://puhep1.princeton.edu/~mcdonald/examples/patents/miessner\\_1915858.pdf](http://puhep1.princeton.edu/~mcdonald/examples/patents/miessner_1915858.pdf)
- [6] G.D. Beauchamp, *Electrical Stringed Musical Instrument*, US Patent 2089171 (filed June 2, 1934),  
[http://puhep1.princeton.edu/~mcdonald/examples/patents/beauchamp\\_2089171.pdf](http://puhep1.princeton.edu/~mcdonald/examples/patents/beauchamp_2089171.pdf)
- [7] Rickenbacker International Corporation, *The Earliest Days of the Electric Guitar*,  
[http://www.rickenbacker.com/history\\_early.asp](http://www.rickenbacker.com/history_early.asp)
- [8] S. Vasilach, *Means for Amplifying Mechanical Vibrations*, US Patent 2293372 (filed Aug. 8, 1939),  
[http://puhep1.princeton.edu/~mcdonald/examples/patents/vasilach\\_2293372.pdf](http://puhep1.princeton.edu/~mcdonald/examples/patents/vasilach_2293372.pdf)
- [9] M.R. Convery and K.T. McDonald, *Noncontact measurement of the tension of a wire* (April 14, 1996), <http://puhep1.princeton.edu/~mcdonald/examples/pluck.pdf>
- [10] J.D. Tillman, *Response Effects of Guitar Pickup Position and Width*,  
<http://www.till.com/articles/PickupResponse/index.html>
- [11] See, for example, H.E.W. Lemme, *The Secrets of Electric Guitar Pickups*,  
<http://buildyourguitar.com/resources/lemme/>
- [12] H.V. Sorensen *et al.*, *Real-Valued Fast Fourier Transform Algorithms*, IEEE Trans. Acoustics, Speech and Signal Processing **35**, 849 (1987),  
[http://puhep1.princeton.edu/~mcdonald/examples/EM/sorensen\\_ieeeassp\\_35\\_849\\_87.pdf](http://puhep1.princeton.edu/~mcdonald/examples/EM/sorensen_ieeeassp_35_849_87.pdf)  
The Fortran source code is available as <http://faculty.prairiestate.edu/skifowit/fft/>
- [13] See, for example, *Synth Secrets, Part 28: Synthesizing Plucked Strings*,  
<http://www.soundonsound.com/sos/aug01/articles/synthsecrets28.asp>
- [14] N.G. Horton and T.R. Moore, *Modeling the magnetic pickup of an electric guitar*, Am. J. Phys. **77**, 148 (2009),  
[http://puhep1.princeton.edu/~mcdonald/examples/EM/horton\\_ajp\\_77\\_148\\_09.pdf](http://puhep1.princeton.edu/~mcdonald/examples/EM/horton_ajp_77_148_09.pdf)